

IMPORTANTES MESURES DE SECURITÉ

LISEZ COMPLÈTEMENT LE MODE D'EMPLOI AVANT
D'UTILISER CE SYSTÈME D'ASPIRATEUR.

En employant un appareil électrique, des précautions fondamentales devraient toujours être prises, y compris:

AVERTISSEMENT

Pour réduire les dangers de feu, d'électrocution, ou de blessure:

- Débrancher et couper le courant avant de le réparer.
- Ne pas utiliser sur des surfaces mouillées.
- Ne pas utiliser comme jouet et surtout faire attention quand on l'emploie près des enfants.
- Employer seulement tel que décrit dans ce manuel d'emploi et qu'avec les accessoires du fabricant.
- Ne pas utiliser si la corde ou la prise électrique est endommagée. Si l'appareil ne fonctionne pas, est endommagé, est tombé par terre, a été laissé à l'extérieur, ou a été immergé, dans l'eau, veuillez rapporter l'appareil à un centre de service.
- Ne pas tirer sur le cordon électrique. Ne pas utiliser le cordon électrique comme poignée, ni le coincer dans une porte ou l'appuyer sur des coins et boudures tranchants. Ne pas passer l'aspirateur sur le cordon électrique. Eloigner le cordon électrique de la chaleur.
- Ne pas débrancher en tirant sur le cordon électrique. Pour le débrancher, saisir la prise de courant, et non le cordon électrique.
- Ne pas utiliser avec les mains mouillées.
- Ne rien mettre dans les fentes et les orifices bouchés. Ne pas employer avec des orifices bouchés. Éliminer poussière, cheveux et les autres choses qui peuvent rendre difficile la circulation d'air.
- Gardez cheveux, vêtements amples, doigts, et toutes autres parties du corps loin des orifices et des pièces mobiles.
- Ne pas aspirer quelque chose qui brûle ou fume, comme des cigarettes, des allumettes, ou des cendres chaudes.
- Brancher à une prise de courant munie d'une mise à la terre. Voir les renseignements de mise à la terre.
- Éteindre tous les contrôles avant de débrancher.
- Faire bien attention en nettoyant les escaliers.
- Ne pas utiliser pour aspirer des liquides inflammables comme l'essence et ne pas employer dans des endroits où ces choses peuvent se trouver.
- Ne rien placer ou entreposer sur le dessus de l'appareil - une surchauffe du moteur pourrait se produire.

CONSERVEZ CES INSTRUCTIONS

**USAGE RESERVÉ POUR LA MAISON OU EMPLOI
COMMERCIAL LÉGER**

*Ne pas ventiler dans un mur, un plafond, ou un espace
dissimulé d'un bâtiment ou un édifice.*

INSTRUCTIONS DE MISE À LA TERRE

Cet appareil doit avoir une mise à la terre. Si une défectuosité ou autre survenait, la mise à la terre offre une voie de moindre résistance au courant électrique, d'où un risque moins élevé d'électrocution. Cet appareil est équipé d'un cordon électrique ayant un conducteur et une fiche de mise à la terre. Cette fiche doit être branchée dans une prise appropriée qui a été installée et mise à la terre convenablement en accord avec le code électrique de votre région

AVERTISSEMENT

Un branchement incorrect de l'équipement de mise à la terre peut causer un risque d'électrocution. Si vous avez un doute concernant la mise à la terre de votre prise, veuillez faire vérifier votre installation par un électricien qualifié ou une personne du service après-vente. Ne pas modifier la fiche fournie avec l'appareil - si la fiche ne se branche pas à la prise, faites installer une prise adéquate par un électricien qualifié.

Les appareils, modèle 760 & 960 doivent être employés avec un circuit de 120 volts et avoir une prise qui ressemble à la prise illustrée sur l'image A.

Les appareils, modèle 780 & 980 doivent être employés avec un circuit de 240 volts et avoir une prise qui ressemble à la prise illustrée sur l'image B.

Vérifiez que votre appareil est branché sur une prise ayant la même configuration que la fiche électrique. Aucun adaptateur ne devrait être utilisé avec cet appareil.

Ne brancher l'appareil qu'à une prise avec mise à la terre.



OPERATING INSTRUCTIONS

FOR MODELS 760/960 & 780/980

MODÈLE A

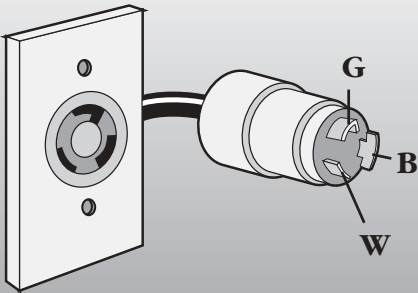

MÉTHODE DE MISE À LA TERRE

MODÈLE B

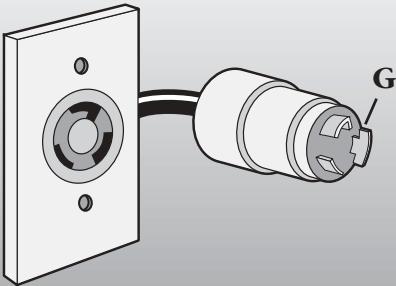

MÉTHODE DE MISE À LA TERRE

READ MANUAL BEFORE OPERATING SYSTEM

TO THE OWNER:

Read the owner's manual thoroughly to ensure the most efficient use of your VACUFLO system. To register your VACUFLO system warranty in the United States and Canada, call 1-800-822-9277, register online (www.vacuflo.com) or fill in and mail the warranty card located with this manual.

Please be sure this manual and warranty information are left with the power unit or customer when installation is complete.



ATTENTION:
NE PAS UTILISER
SUR TAPIS OU
PLANCHER
MOUILLE.





MODELS 760/780 & 960/980
COMMERCIAL
AND OVERSEAS
LIMITED WARRANTY

The manufacturer warrants to the initial purchaser that the VACUFLO Models 760/780 and 960/980 power units will be free from defects in material and workmanship for one (1) year from the date of first consumer purchase and that hoses, tools, turbine attachments and other attachments will be free from defects in material and workmanship for ninety (90) days from the date of first purchase.

Defects, malfunctions, failure, or damage caused by improper, unreasonable, or negligent use or repair while the warranted parts are in possession of the purchaser are excluded from the warranty. This warranty does not cover unauthorized removal or repair of the motor assembly.

THIS WARRANTY IS EXPRESSLY IN LIEU OF ANY OTHER WARRANTIES, EXPRESS OR IMPLIED, INCLUDING THE IMPLIED WARRANTIES OF MERCHANTABILITY OR FITNESS FOR A PARTICULAR PURPOSE. THIS WARRANTY DOES NOT COVER THE INSTALLATION OF EQUIPMENT. IN NO EVENT SHALL THE MANUFACTURER BE LIABLE FOR ANY OTHER OBLIGATIONS OR LIABILITIES ESPECIALLY FOR ANY INCIDENTAL OR CONSEQUENTIAL DAMAGES TO ANYONE. THE WARRANTY DOES NOT COVER UNAUTHORIZED REMOVAL OR REPAIR OF THE MOTOR ASSEMBLY.

Some states/provinces do not allow the exclusion or limitation of incidental or consequential damages so the above limitation or exclusion may not apply to you. We neither assume nor authorize any person to assume for us any liability in connection with the sale or service of the VACUFLO equipment other than as provided in this warranty. This warranty is only valid under normal, intermittent use of the product when properly installed and operated in light commercial application.

IMPORTANT WARRANTY INFORMATION

Proof of Purchase or Registration of the VACUFLO System is required before any warranty work will be performed by an Authorized VACUFLO Dealer. Registration ensures a fast and easy resolution to your warranty requirements.

To register, simply call the 24-hour VACUFLO registration line at 1-800-822-9277, register online (www.vacuflo.com) or complete and return the blue warranty postcard located in this VACUFLO Owner's Manual.



512 West Gorgas Street • P.O. Box 3912
Louisville, OH 44641-3912
1-800-822-8356
www.vacuflo.com

VACUFLO® Built - In Central Vacuum Systems OPERATING INSTRUCTIONS

VACUFLO® True Cyclonic MODELS: 760/9

General Information

Do Not Store Objects on top of the power unit. This will block the motor cooling ventilation. Restricting the cooling airflow may shorten the motor life.

The central vacuum is designed to vacuum ordinary household dirt and dust. The system is designed for dry pickup. A Wetvac accessory is needed if the system will be used for liquid pickup.

The central vacuum system is a network of inlet valves, 2" PVC tubing, and low voltage wiring installed in the walls of your home. To operate the system, simply plug the hose into an inlet valve, attach the cleaning tool to the curved hose end and begin vacuuming. The dirt is transported through the in-wall tube system back to the dirt canister (located on the power unit).

Caution: *Do not allow the motor to remain turned on, unless a hose is connected or an inlet valve is open. If air is not permitted to pass through the fan blades, damage may occur to the motor.*

Operating Instructions

Using the Central Vacuum System is easy. Simply raise the inlet valve lid, insert the hose end and attach the desired cleaning tool to the hose wand. The Power Unit is activated when the hose is inserted into the valve.

General Power Unit Maintenance

The simple care and maintenance instructions included here will help ensure trouble-free use of the central vacuum system.

- Do not place objects on top of the power unit. The motor could overheat.
- Do not allow the motor to remain "on" unless a hose is connected or an inlet valve is open. If airflow is not permitted to flow through fan blades, motor damage may occur.
- Empty the dirt canister when it is 3/4 full.
- Remember to clean the motor guard screen each time the dirt receptacle is emptied. (refer to Cleaning Guard Screen instructions).
- The power unit does not require any lubrication.
- The exterior of the power unit can be wiped with a clean, dry cloth. Do not use liquid cleaners or water as an electrical shock may occur.
- For additional service contact a qualified service person.

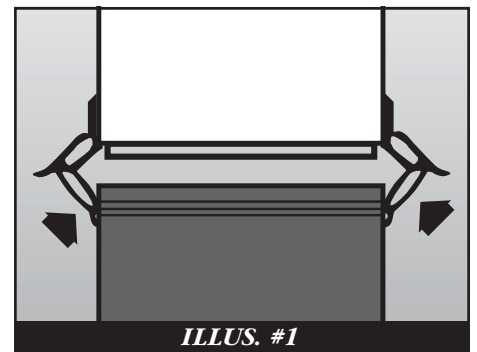

ILLUS. #1

Emptying the Dirt Canister & Cleaning the Guard Screen

The dirt canister – where the vacuumed dirt is deposited – is the removable lower portion of the power unit. The canister needs to be removed and emptied when it is 3/4 full. The Motor Guard Screen should be cleaned each time you empty the dirt canister.

The motor guard screen is located directly above the dirt canister inside the power unit. The guard screen is not removable, it is designed to prevent lightweight fibers from entering the motor impeller blades. A buildup of material on the guard screen may result in a loss of vacuum.

Follow these steps to empty the dirt canister

(refer to illustration #1)

Make sure the Power Unit is OFF.

- 1) Disengage the canister latches located on opposite sides of the power unit.
- 2) Remove the dirt canister.
- 3) Dispose of canister contents in trash receptacle.
- 4) Clean the guard screen.

c /960 & 780/980

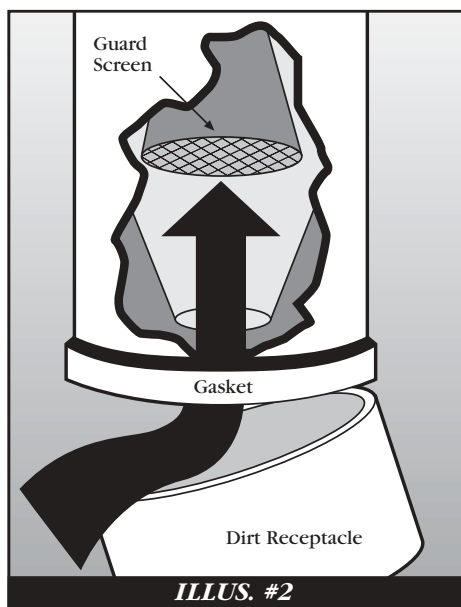

- 5) Raise the empty dirt canister to the proper location under the power unit and engage the latches.
- 6) Be certain the dirt canister is “seated” properly to the gasket on the body of the power unit.

Follow these steps to Clean the Guard Screen

(refer to Illustration #2)

A long handled stiff brush is recommended for cleaning the screen. Make sure the Power Unit is OFF.

- 1) Unlatch and remove the Dirt Canister. (Hold or place the canister under the power unit to catch the debris removed from the guard screen.)
- 2) Using a long handled brush, insert the brush through the bottom of the dirt cone reaching to the guard screen. Gently “sweep” the screen to remove the debris.

- 3) Dispose of the dirt and debris captured in the dirt canister.
- 4) Raise the dirt canister to the proper location under the power unit and engage the latches.
- 5) Be certain the dirt canister is “seated” properly to the gasket on the body of the power unit.

Troubleshooting the system

Motor Fails to Turn On:

- Check the main fuse or circuit breaker at the main power supply panel of your home. Reset breaker or replace fuses if necessary.
- Check the Power unit reset button located above the power cord. Pressing the button should restore operation.
- If the circuit protector continues to trip off after a short period of time, the motor brushes may be worn out. Call a qualified service person for service.

Loss of Vacuum

If the system shows a loss of vacuum power, check the following:

- The dirt receptacle and motor guard screen may need cleaned – follow instructions in this guide.
- The hose may be clogged – To check if there is an obstruction, unplug the hose and insert an object that is smaller than the diameter of the hose (A butter knife works well). Pass the object completely through the hose, if it stops that will indicate where the obstruction

is located. A dry garden hose can be inserted into the hose to help push obstruction through.

- The Dirt Canister may not be properly seated to the gasket – Follow instructions for replacing the dirt canister.
- Tube lines may be obstructed – First check the 90 degree elbow located directly behind the inlet valves, if an obstruction occurs it will usually not make it past this elbow. If the obstruction is not visible at the elbow, attempt to purge the tubing at each inlet valve. To do this, connect the hose and use your hand to stop airflow at the end of the hose for a couple seconds, let airflow resume. Repeat if necessary.
- If necessary call a qualified service person to perform required maintenance.

Obtaining Service Under Warranty:
To obtain repair on warranted parts contact the seller of the system with the power unit serial number.

IMPORTANT SAFETY INSTRUCTIONS

READ ALL INSTRUCTIONS BEFORE USING THIS VACUUM SYSTEM

When using an electrical appliance, basic precautions should always be followed, including the following:

WARNING

To reduce the risk of fire, electric shock or injury:

- Unplug and disconnect power before servicing.
- Do not use on wet surfaces.
- Do not allow to be used as a toy. Close attention is necessary when used by or near children.
- Use only as described in this manual. Use only manufacturer's recommended attachments.
- Do not use with damaged cord or plug. If appliance is not working as it should, has been dropped, damaged, left outdoors, or dropped into water, return it to a service center.
- Do not pull or carry by cord, use cord as a handle, close a door on cord, or pull cord around sharp edges or corners. Do not run appliance over cord. Keep cord away from heated surfaces.
- Do not unplug by pulling on cord. To unplug, grasp the plug, not the cord.
- Do not handle system or appliance with wet hands.
- Do not put any object into openings. Do not use with any opening blocked. Keep openings free of dust, lint, hair, and anything that may reduce air flow.
- Keep hair, loose clothing, fingers, and all parts of body away from openings and moving parts.
- Do not pick up anything that is burning or smoking, such as cigarettes, matches, or hot ashes.
- Connect to a properly grounded outlet. See grounding instructions.
- Turn off all controls before unplugging.
- Use extra care when cleaning on stairs.
- Do not use to pick up flammable or combustible liquids such as gasoline or use in areas where they may be present.
- **Do not place or store anything on top of power unit - overheating of motor could occur.**

SAVE THESE INSTRUCTIONS

INTENDED FOR HOUSEHOLD AND LIGHT COMMERCIAL USE.

Do not vent into a wall, a ceiling, or concealed space of a building or structure.

Connect to a properly grounded outlet only.

GROUNDING INSTRUCTIONS

This appliance must be grounded. If it should malfunction or breakdown, grounding provides a path of least resistance for electric current to reduce the risk of electric shock. This appliance is equipped with a cord having an equipment grounding conductor and grounding plug. The plug must be plugged into an appropriate outlet that is properly installed and grounded in accordance with all local codes and ordinances.

WARNING

Improper connection of the equipment-grounding conductor can result in a risk of electric shock. Check with a qualified electrician or service person if you are in doubt as to whether the outlet is properly grounded. Do not modify the plug provided with the appliance - if it will not fit the outlet, have a proper outlet installed by a qualified electrician.

The Models 760 & 960 appliance is for use on a nominal 120 volt circuit and has a grounding plug that looks like the plug illustrated in Fig. A.

The Models 780 & 980 appliance is for use on a nominal 240 Volt circuit and has a grounding plug that looks like the plug illustrated in Fig. B.

Make sure that the appliance is connected to an outlet having the same configuration as the plug. No adapter should be used with this appliance.

FIG. A

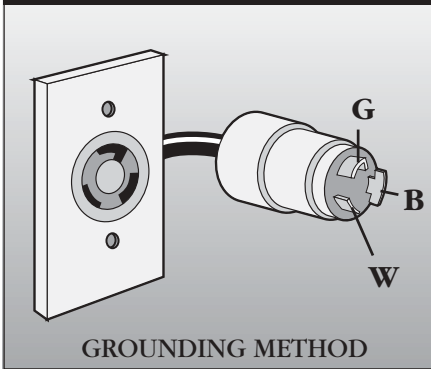
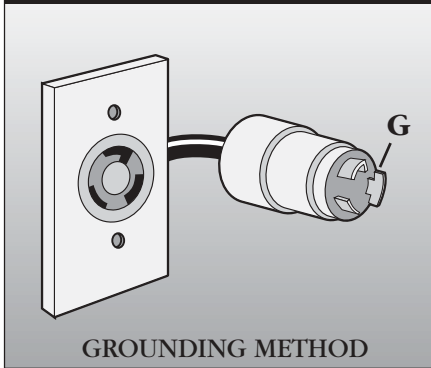

FIG. B



MODELS 760/780 & 960/980

LIFETIME PLUS 3 RESIDENTIAL LIMITED WARRANTY

All permanently installed components of the VACUFLO Built-In Central Vacuum System are warranted to be free from defects in material and workmanship under normal use and care as long as the original consumer purchaser owns the home of original installation or until the system is removed from its' original installation, whichever occurs first.

In the event of a defect in permanently installed components of the VACUFLO System, an authorized VACUFLO dealer should be contacted. The dealer will repair or replace (at our option) any defective part or parts at your location at no labor cost for a period of three (3) years. Thereafter, repaired or replacement (at our option) part or parts will be provided to you for any items under warranty.

All VACUFLO accessories are warranted to be free from defects in material and workmanship under normal use and care for three (3) years from date of original consumer purchase. In the event of a defect in a VACUFLO accessory, the accessory will be repaired or replaced (at our option) at an authorized VACUFLO dealer location at no labor costs for three (3) years. There is no warranty for consumable items such as light bulbs, belts, and beater brushes.

THIS WARRANTY IS A SOLE AND EXCLUSIVE WARRANTY. ALL OTHER WARRANTIES INCLUDING IMPLIED WARRANTIES OF MERCHANTABILITY OR FITNESS FOR A PARTICULAR PURPOSE ARE EXCLUDED. THIS WARRANTY COVERS ONLY LIABILITY AND RESPONSIBILITY DESCRIBED HEREIN AND THERE IS NO LIABILITY FOR ANY CONSEQUENTIAL, INCIDENTAL OR SPECIAL DAMAGES ARISING FROM THE USE OF THIS SYSTEM.

Some states do not allow exclusion or limitation of warranties or limitation of incidental or consequential damages so the above exclusion may not apply to you. This warranty gives you specific legal rights and you may have other rights which vary from state to state.

To register as the original consumer purchaser and verify your coverage please return the warranty registration located in the owner's manual or in the United States and Canada, call 1-800-822-9277. Register online (www.vacuflo.com)



WARNING:
ELECTRIC SHOCK
COULD OCCUR IF
USED ON WET
SURFACES.

CAUTION:
DO NOT USE ON
WET RUG OR
FLOOR.

Above logos do not apply to models 780 & 980